

# Diala, Jour, Volume, 37, 2009

## "Cutting mild steel by Carbon dioxide laser"

**Asst.Instructor.Jasim Hassan Rasheed**  
**Physics department , Science College ,**  
**University of Diyala**

**Abstract:** The aim of this reserch is to present a correlations between different cutting Parameters such as, cutting speed , laser power and oxygen gas pressure. An investigation to define the minimum power for a Particular speed is carefully made . The present results may extend the existing view that Co<sub>2</sub> laser is an excellent cutting tool.

1. **Introduction** : In recent years there have been many advances in the field of laser cutting. It is an attractive field for industry due to its many advantages over the other heat sources such as, plasma torch and electron beam. During 1968-1970 a major step was made towards using the carbon dioxide laser in metal cutting , Particularly with the group of metals which reacts exothermally with oxygen. This achievement was characterized by the introduction of the gas – assisted method by Houldcroft (1). In the following years many workers (1-12) reported a wide range of available results directly applicable to the laser gas jet method. Optimum Conditions such as minimum power and maximum speed for definite thickness needed to be studied to give accurate assessment for both cost

# Diala, Jour, Volume, 37, 2009

and cut efficiency which are required by industry . Therefore investigation of wide range of Parameters covering the Process of cutting using Carbon dioxide laser is described and discussed. The investigation includes a study of the main Parameters Known to influence the cutting process such as Power , speed and pressure.

## **2.The parameters of cutting process:**

A graphical relationship between parameters mentioned above are produced . This relationship may help in understanding the cut process and can be considered another step toward supporting the idea of using the laser beam as an efficient thermal energy source . The main parameters are:

a) **Power:** The maximum power available is about 500w.

b) **Cutting speed :** The maximum speed is 33.334 mm /sec . cutting speed is expressed as a percentage throughout these calculations , viz 5% , 25%..... u% Table (1) shows the true speed related to maximum speed .

Table (1)

U%	Uin mm /s
05	1.667
25	8.335
50	16.667
75	25.005
100	33.334

# Diala, Jour, Volume, 37, 2009

c) **Pressure** : The maximum pressure that could be applied was 40 psi . The range of pressures used was (5-40) psi which is the range used in industrial laser cutting.

d) **metal**: The metal used was mild steel sheet ( grade CR4) with thicknesses of 1.68, 2.0 and 2.5 mm.

The above main parameters were selected due to their direct linear influence on the process.

It is necessary to point out that the laser was focused on the metal's surface in this work, and laser cutting head showing laser beam path is shown in figure (1) as mentioned in (11) .

## 3- **Results and Discussion**

a) **Relationship between laser power and laser cutting speed (10).**

The Variation of minimum laser power with cutting speed for different pressures and for given thickness (1.68mm) of mild steel is shown in figure (2). It is evident that the minimum power for certain thickness and pressure is proportional to the cutting speed (2) .The minimum power may be called the threshold power , below which a complete cut is not possible. When the cutting speed increases , the interaction time decreases . As the interaction time becomes shorter, less laser power is available to strike the irradiated area, also less exothermic energy is produced since less oxygen gas reacts with the metal . Therefore a thinner molten layer is created.

# Diala, Jour, Volume, 37, 2009

As the cutting speed increases the thickness of the molten layer becomes thinner and complete cutting may stop . To cut the same thickness with higher speed ,the laser power required should be increased at same oxygen gas pressure .

Similar trends are shown to figure (2) during cutting thicker samples as shown in figures (3) and (4) .

Houldcroft (1) reported that the cutting speed increases out of proportion to laser power which is in a similar way to the present work and shown in his table (2) given below:

Thickness (mm)	Laser power (w)	Cutting speed mm/s
0.76	250	23.0
0.76	190	07.2
1.52	250	07.2

Gonsalves and Duley (4) showed that the variation of the critical cutting speed is proportional to power for variour sheet thicknesses.

However ,figure (2) shows a major role for oxygen gas pressure on laser power employment on particular cutting speed. Explaining oxygen gas pressure is mentioned next section.

## **b) Relationship between gas pressure , and both laser power and cutting speed (10) :**

Figure (2) shows that the minimum laser power required to complete the cutting process is inversely Proportional to the

## Diala, Jour, Volume, 37, 2009

gas assisting pressure while cutting speed is Proportional to the gas pressure . This can be explained as follows , during cutting mild steel by Co<sub>2</sub> laser , oxygen gas pressure has three functions .

i)It produces condition of the heated surface which in turn increases the absorption of the beam.

ii) The oxygen then oxidizes the heated metal , and the heat of the reaction , which is usually exothermic , greatly enhances the cutting action and helps to keep the oxide molten . In other words , the gas jet generated an additional thermal energy during oxidization of steel . This thermal energy enhances the cutting speed .

iii)The molten oxide is removed from the cutting zone by the momentum of the oxygen jet or by shear force to the gas- liquid boundary to inject the molten metal formed during the cutting process (7 ,8 ) . The momentum of the gas increases as the gas pressure increases . In fact the variation of the jet momentum is significant cant not only in relation to the removed of the molten fluid from the cutting curve but also because of its effect on the heat transfer to the bulk of the both liquid metal and the rest of the work piece .

For a particular cutting speed , increasing gas pressure decreases the liquid layer thickness the pressure of the liquid layer at cut front is considered a big problem . The

## Diala, Jour, Volume, 37, 2009

heat conduction in the direction of the cut depends on the molten layer thickness. The heat conduction of mild steel liquid is poorer than that of the solid . Therefore the thickness should be reduced to a minimum , in order to ensure sufficient heat is conducted in the cutting direction.

As a result less laser power is needed to keep the cutting process going at the same speed. Conversely , if the jet momentum is not high enough , the molten layer builds up and may becomes thick enough to reduce heat conduction in the cutting direction . The cutting process may finally stop unless cutting speed decreases or the laser power increases . when cutting speed decreases the interaction time increases and more energy is expected to be absorbed and conducted in the cut direction . As the pressure increases the chemical reaction between oxygen and metal becomes stronger . The chemical reaction plays a major role in the cutting action by contributing additional energy due to the exothermic reaction . If more exothermic energy is produced at a given speed less laser power is required to cut the same thickness. Thicker samples show similarity to that shown in Figure(2) as can be seen in Figures (3 and 4 ) .Olsen (6) studied the effect of the gas pressure on the cutting process and reached the conclusion that it is possible to increase the cutting speed by increasing gas pressure . In addition , the same author stated that increase of the cut speed due to higher

# Diala, Jour, Volume, 37, 2009

pressure seems to be more effective than using higher power. Dulry and Gonsalves (5) express the opinion that increasing the gas pressure would increase the cutting speed up to a maximum after which further increase in gas pressure causes a fall in cutting speed.

The author attributed the lowering of cutting speed at high pressure to the cooling effect of the high gas pressure and presence of the shock waves in the jet. Due to the shock wave the density across the gas jet is not the same which affects the exothermic energy produced. Figures (2,3 and 4) show no sign of cooling affect at all.

**3) Conclusion** As far as the laser power enough and the metal is capable of absorbing the required energy, the maximum cut speed can be increased unless the gas pressure acts as a cooler rather than an energy supplier.

In general, the oxygen gas pressure played a major role in decreasing laser power but increasing cutting speed which is very important for production cost. However, interdependency between basic laser cutting speed parameters mentioned in this research could be summarized in table (3) :

Co2laser power	Cutting speed	Oxygen gas Pressure	Thickness ( mild steel)
Increasing	Increasing	Constant	Constant
Constant	Increasing	Increasing	Constant
Decreasing	Constant	Increasing	Constant
Increasing	Constant	Constant Increasing	Increasing

Table (3)

## خلاصة البحث :

الهدف من هذا البحث ، دراسة قطع الفولاذ بـ ليزر ثاني اوكسيد الكربون وتركز البحث على ايجاد علاقة مباشرة بين اهم العوامل المؤثرة في عملية القطع هذه ، وخاصة السرعة والقدرة الليزرية ، اضافة الى ضغط الغاز " غاز الاوكسجين " حيث اظهر الاوكسجين اثرا بالغاً على عوامل القطع اعلاه ، كما اعطت الدراسة اهمية لاحتساب اقل قدره ممكن توظيفها لسرعة قطع معينة .

نأمل ان تسهم هذه الدراسة في تأكيد اهمية ليزر ثاني اوكسيد الكربون في عملية قطع المعادن وخاصة الفولاذ ومدى امكانية التوسع بها لاغراض التكنولوجيا الحديثة .



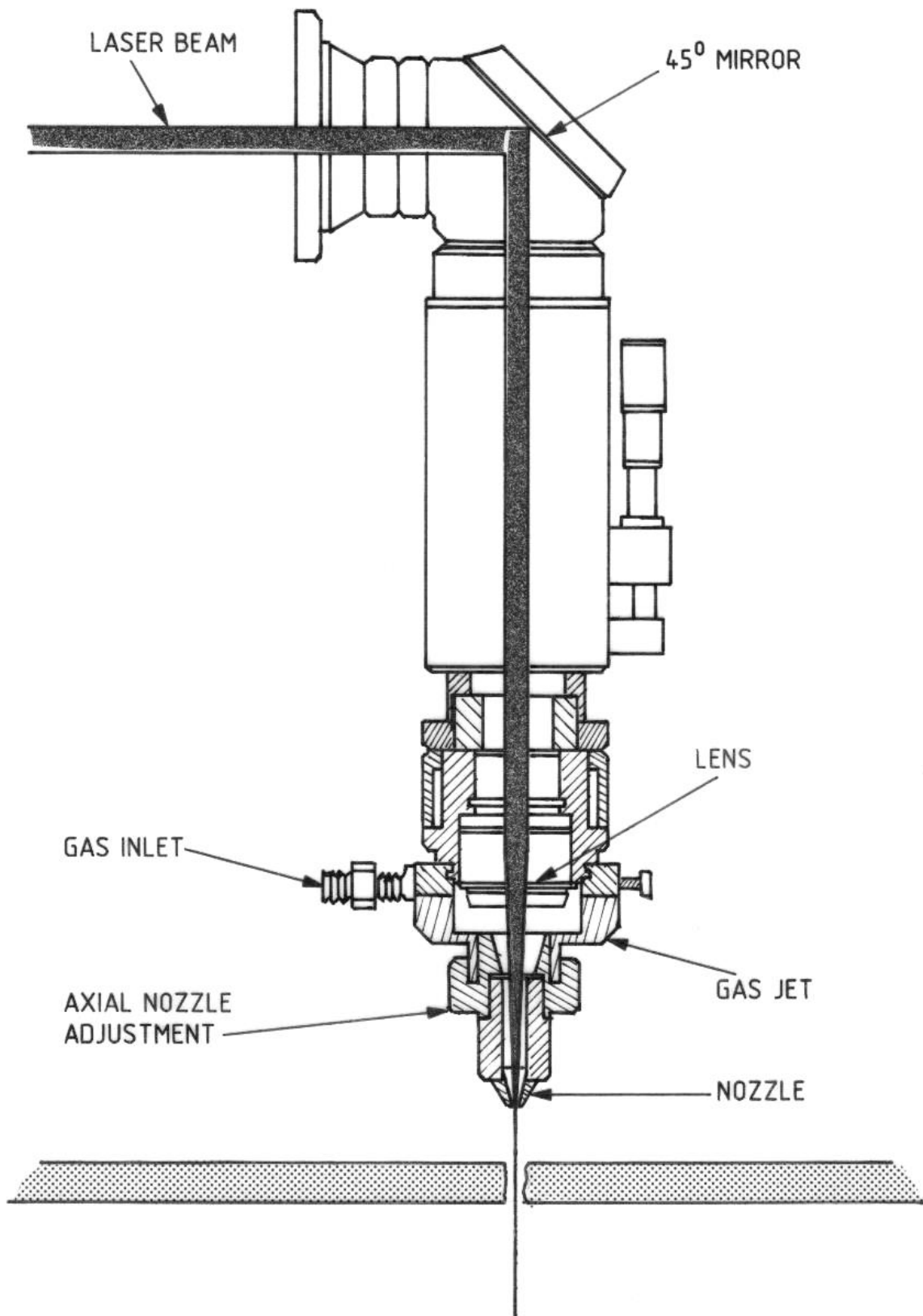

Fig. 4. 2. Laser cutting head showing laser beam path. (after J. Powel 76)

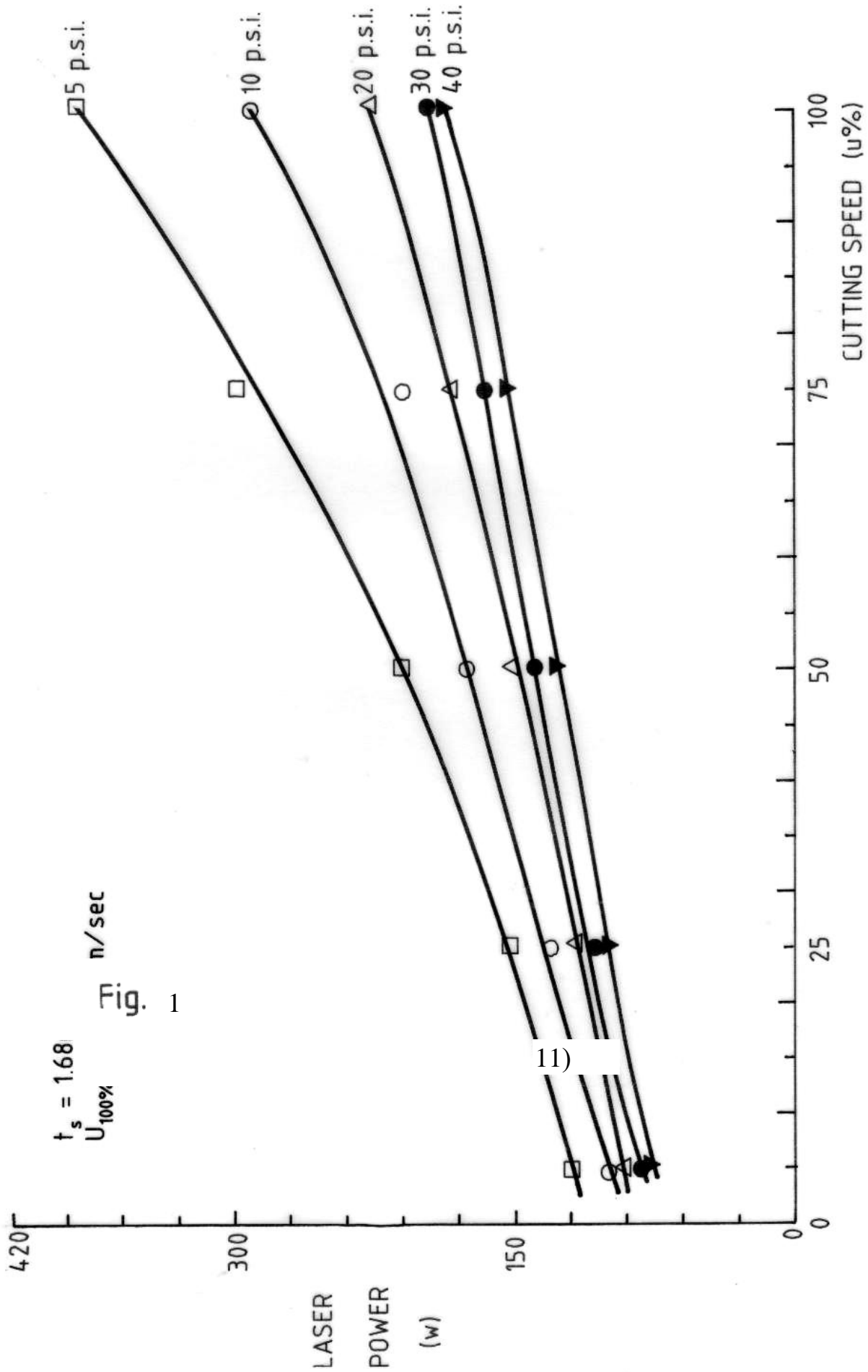

Fig. 5. 1. Variation of the laser power with cutting speed

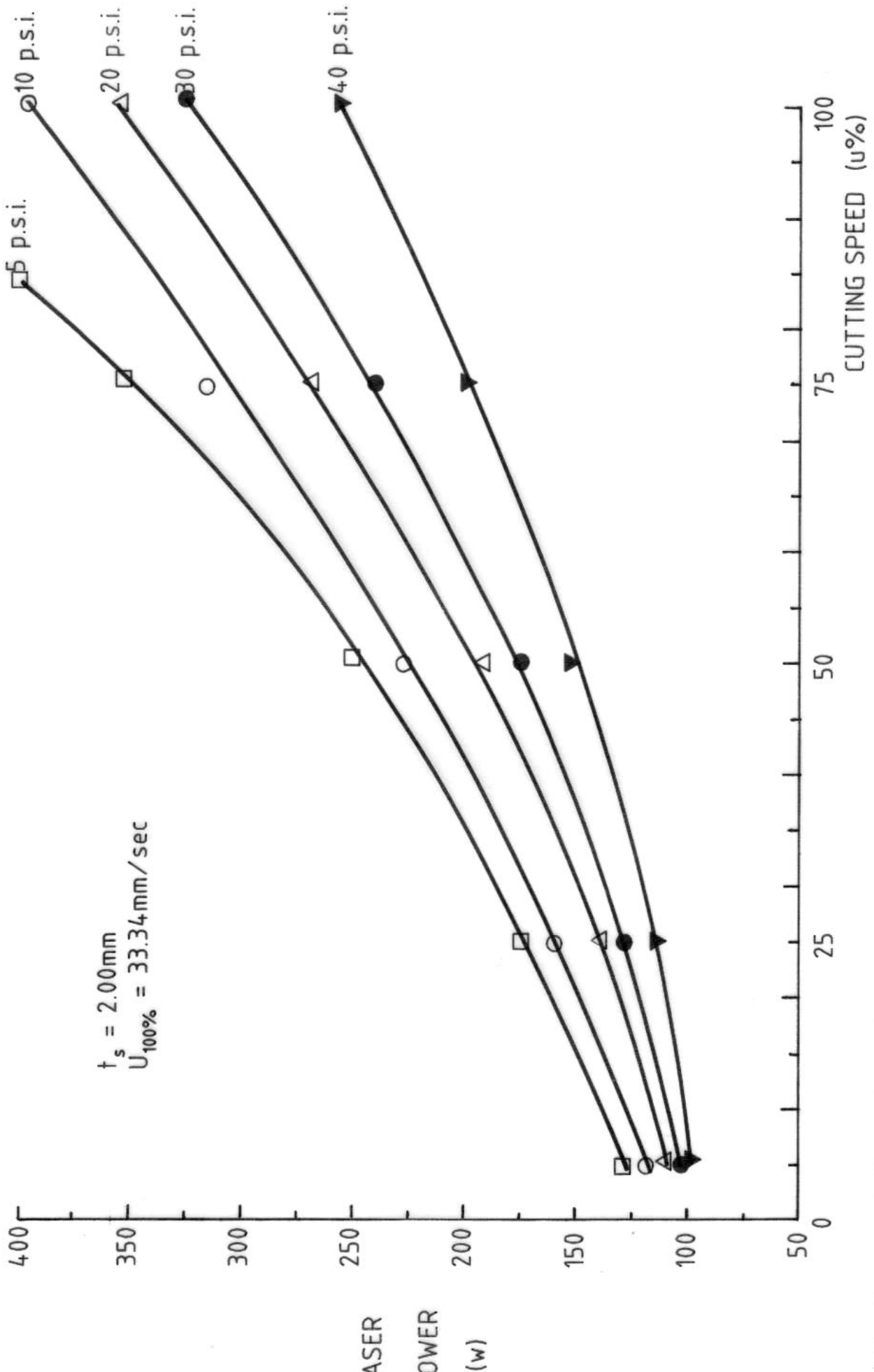

Fig. 5. 2. Relationship between the laser power and cutting speed.

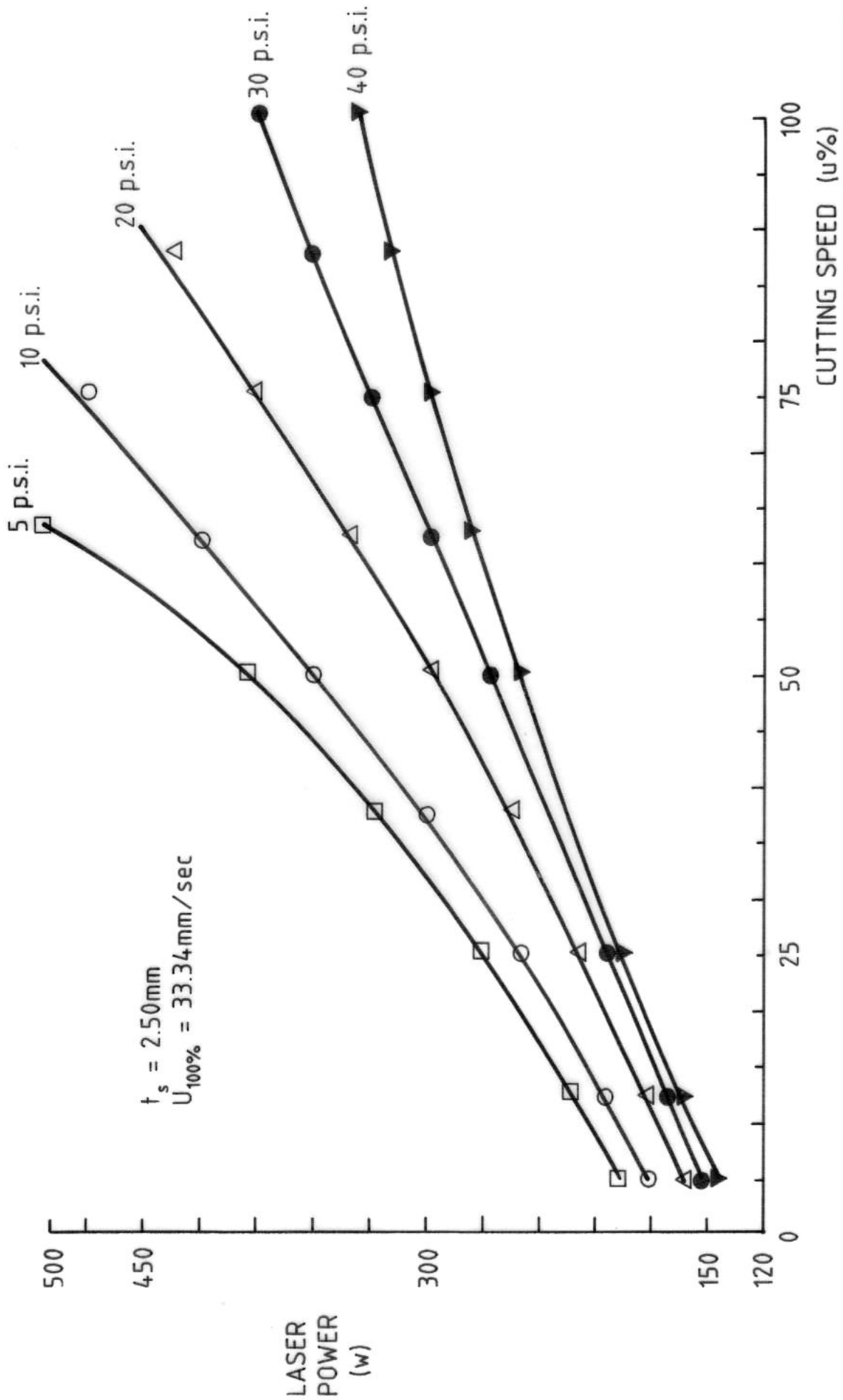

Fig. 5. 3. Variation of the laser power with the cutting speed.

# Diala, Jour, Volume, 37, 2009

## **References :**

- 1- Houldcroft . P. T. " metal cutting by oxygen –assisted laser " opt. tech . vol (1) (1968)
- 2- Arata, y " Some fundamental properties of high power Cw laser beam as heat Source" (1969. )
- 3- Houldcroft, P. T" The importance of the laser cutting and welding" weld and metal, PP (42-46 ), (1972 .)
- 4- Gonsalves, J . N and Duely , w .w " cutting thin metal sheets the cw Co<sub>2</sub> laser" phys. Vol.43.PP (4684 – 87) , (1972).
- 5- Dulley, W. W and Gonsalves , J .N." Co<sub>2</sub> laser cutting of thin metal sheets gas jet assist." Opt and laser tech (1974).
- 6- Olsen ,F.O, Emmel, A and Bergman,H.W."Contribution to oxygen assisted Co<sub>2</sub> laser cutting" proc.6<sup>th</sup>.conf. lasers in manufacturing, UK , pp (67 – 79) , (1989)..
- 7- Yilbas . B. S. Kar " thermal and efficiency analysis . of Co<sub>2</sub> cutting process opt lasers Eng . pp(17-32)(1998).
- 8- Tirumala Rao and A.k Nath " Melt flew characteristic in gas – assisted laser cutting " Center for advanced Technology . Indore 452013, India Sadhana vol. 27 part 5 oct. pp (569 – 575 ). (2002 ).

# Diala, Jour, Volume, 37, 2009

- 9- Neill, W. and Gabzdy1 , J.T "New development in laser assisted oxygen cutting " opt. and laser in Eng. Vol . 34 .pp (355-367) , (2005).
- 10-Jasim . H Rasheed " Private work " Mechanical. Eng., Loughborough Univ. Uk (1989).
- 11.powel. J.and Menzies .A "principle and application of CO<sub>2</sub> lasers cutting ". material eng. Conf. London, Nov.(1985).
- 12.Michael .L, Cadorette and Fred Walker. H.  
"characterizing productivity of (4) Kw,CO<sub>2</sub> laser cutting system for mild steel"  
The official electronic publication of the national association of industrial Technology (2006).